



Electrolux

Modular Cooking Range Line 700XP Full Module Gas Fry Top, Mild Steel

ITEM # _____

MODEL # _____

NAME # _____

SIS # _____

AIA # _____



Electrolux

Modular Cooking Range Line
700XP Full Module Gas Fry Top, Mild Steel



Modular Cooking Range Line

700XP Full Module Gas Fry Top, Mild Steel

371031 (E7FTGHSS00)	700XP FULL MODULE GAS FRY TOP, SMOOTH PLATE, MILD STEEL
371032 (E7FTGHSP00)	700XP FULL MODULE GAS FRY TOP, 2/3 SMOOTH - 1/3 RIBBED PLATE, MILD STEEL

Short Form Specification

Item No. _____

To be installed on open base installations or bridging supports. Smooth cooking surface in mild steel. Suitable to be used with Natural or LPG gas. Temperature range from 200°C to 400°C. Removable drawer below the cooking surface for the collection of grease and fat. Exterior panels in stainless steel with Scotch Brite finish. One piece pressed work top in 1.5 mm thick stainless steel. Right-angled side edges to allow flush-fitting junction between units.

Main Features

- Unit to be mounted on open base cupboards, bridging supports or cantilever systems.
- Large drain hole on cooking surface permits the draining of fat into large 1,5 liter collector placed under the cooking surface.
- Large grease collection container available as optional accessory to be installed under top units over open base cupboard.
- Regulators with fixed high and low positions for precise control.
- Stainless steel high splash guard on the rear and sides of cooking surface. Splash guard can be easily removed for cleaning.
- Scrapers with smooth or ribbed blades included as standard.
- Piezo spark ignition for added safety.
- Temperature range of griddle from 200 °C to 400 °C.
- Gas appliance supplied for use with natural or LPG gas, conversion jets supplied as standard.
- IPX 4 water protection.

Construction

- Cooking surface in mild steel for optimum grilling results.
- Cooking surface to be completely smooth or 2/3 smooth and 1/3 ribbed.
- All exterior panels in Stainless Steel with Scotch Brite finishing.
- One piece pressed 1.5 mm work top in Stainless steel.
- Model has right-angled side edges to allow flush fitting joints between units, eliminating gaps and possible dirt traps.

Optional Accessories

- Scraper for smooth plate fry tops PNC 164255
- Scraper for ribbed plate fry tops (only for 371032) PNC 164257
- Draught diverter with 150mm diameter PNC 206132
- Matching ring for flue condenser PNC 206133
- 4 wheels, 2 swivelling with brake (700/900XP). It is mandatory to install with base supports for feet/wheels. PNC 206135
- Support for bridge type system, 800mm PNC 206137
- Support for bridge type system, 1000mm PNC 206138
- Support for bridge type system, 1200mm PNC 206139

APPROVAL: _____



Electrolux

Modular Cooking Range Line 700XP Full Module Gas Fry Top, Mild Steel

- Support for bridge type system, 1400mm PNC 206140
- Support for bridge type system, 1600mm PNC 206141
- Flue condenser for 1 module, 150 mm diameter PNC 206246
- Water coulumn with swivel arm (water column extension not included) PNC 206289
- Water column extension for 700 line PNC 206291
- Chimney upstand, 800mm PNC 206304
- Right and left side handrails PNC 206307
- Grease/oil kit container for 700 line frytops (half and module) and 900 line frytops (module) PNC 206346
- Base support for feet or wheels - 800mm (700/900) PNC 206367
- Rear paneling - 800mm (700/900) PNC 206374
- Rear paneling - 1000mm (700/900) PNC 206375
- Rear paneling - 1200mm (700/900) PNC 206376
- Chimney grid net, 400mm PNC 206400
- - NOT TRANSLATED - (only for 371032) PNC 206420
- Frontal handrail 800mm PNC 216047
- Frontal handrail 1200mm PNC 216049
- Frontal handrail 1600mm PNC 216050
- Large handrail - portioning shelf, 400mm PNC 216185
- Large handrail - portioning shelf, 800mm PNC 216186
- 2 side covering panels for top appliances PNC 216277
- Pressure regulator for gas units PNC 927225



**Modular Cooking Range Line
700XP Full Module Gas Fry Top, Mild Steel**

The company reserves the right to make modifications to the products without prior notice. All information correct at time of printing.

2014.06.23



Electrolux

Modular Cooking Range Line 700XP Full Module Gas Fry Top, Mild Steel

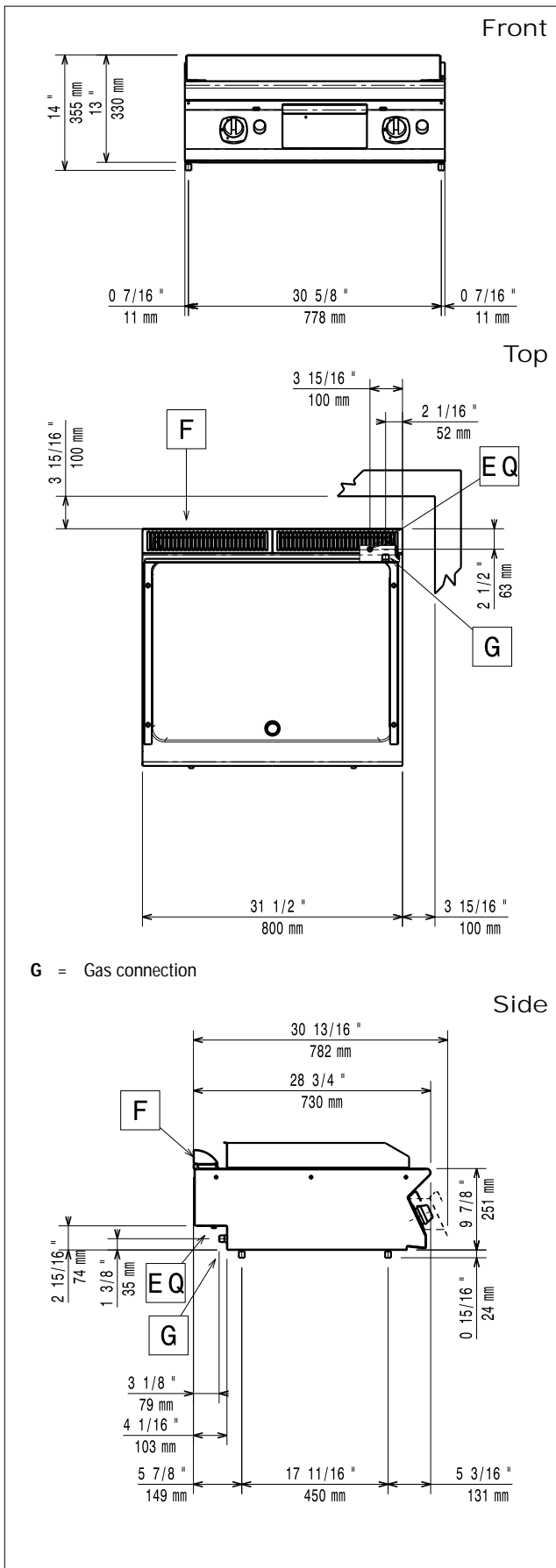

Gas

Gas Power:

371031 (E7FTGHSS00) 47726 Btu/hr (14 kW)

371032 (E7FTGHSP00) 47726 Btu/hr (14 kW)

Gas Type Option:

LPG

Gas Inlet:

1/2"

Natural gas - Pressure:

371031 (E7FTGHSS00) 7" w.c. (17.4 mbar)

LPG Gas Pressure:

371031 (E7FTGHSS00) 11" w.c. (27.7 mbar)

Key Information

Cooking surface width: 730 mm

Cooking surface depth: 540 mm

Working Temperature MIN: 200 °C

Working Temperature MAX: 400 °C

Net weight: 70 kg

Shipping weight:

371031 (E7FTGHSS00) 90 kg

371032 (E7FTGHSP00) 84 kg

Shipping height:

371031 (E7FTGHSS00) 520 mm

371032 (E7FTGHSP00) 540 mm

Shipping width: 820 mm

Shipping depth: 860 mm

Shipping volume:

371031 (E7FTGHSS00) 0.37 m³

371032 (E7FTGHSP00) 0.4 m³

If appliance is set up or next to or against temperature sensitive furniture or similar, a safety gap of approximately 150 mm should be maintained or some form of heat insulation fitted.



Modular Cooking Range Line
700XP Full Module Gas Fry Top, Mild Steel

The company reserves the right to make modifications to the products without prior notice. All information correct at time of printing.