

## Crosswise Convection Gas Convection Oven, 10 GN2/1 - 60Hz

ITEM # \_\_\_\_\_

MODEL # \_\_\_\_\_

NAME # \_\_\_\_\_

SIS # \_\_\_\_\_

AIA # \_\_\_\_\_

**260724 (FCG10260)**

 Gas Convection Oven  
 10x2/1GN, crosswise

### Short Form Specification

#### Item No.

Main structure in stainless steel, with seamless joints in the oven cavity. Double-glazed door with tempered glass. Cavity lighting. Unique air-flow channel system.

Cooking cycles: air convection, convection with 5 stage humidification. Max. temperature of 300°C.

Functional level: base, manual.

"Cross-wise" pan rack suitable for 10x2/1GN or 20x1/1GN. The pan rack, fixed, can be converted into a roll-in rack by using an optional kit.

Supplied with n. 1 pan rack, 60mm pitch (made up of n. 2 side hangers).

### Main Features

- Racks can be easily removed without the need for special tools.
- Unique air-flow system guarantees perfect distribution of heat throughout the oven cavity.
- Maximum temperature of 300°C.
- Food temperature probe available as accessory.
- Rapid cooling of oven cavity.
- Halogen lighting and "crosswise" pan supports allow clear and unobstructed view of the products being cooked.
- 5 Stage humidification control, to ensure perfect pastries and succulent roasts.
- Meets the requirements of CE, VDE and DVGW for safety.

### Construction

- Access to all components from the front.
- Stainless steel oven cavity with rounded corners.
- Double-glazed door with tempered glass.
- External access door for electrical connections.
- All connections made on the left side below the oven.
- Integrated drain outlet.
- IPx4 water protection.

### Included Accessories

- 1 of 60mm pitch side hangers for 10x2/1GN oven (included with the oven) PNC 922123

### Optional Accessories

- Water softener with salt for ovens with automatic regeneration of resin  PNC 921305
- Resin sanitizer for water softener (921305)  PNC 921306
- Fat filter for gas 10 and 20 1/1 and 2/1 GN ovens (2 filters are necessary for 20-grid ovens)  PNC 921700
- Flue condenser for gas ovens 10x1/1-2/1  PNC 921701
- Probe for ovens 10x2/1GN  PNC 921703
- Guide kit for 1/1GN drain pan  PNC 921713
- Pair of grids for whole chicken (8 per grid - 1,2kg each), GN 1/1  PNC 922036
- Base for ovens 10x2/1GN  PNC 922103
- Shelf guides for 10x2/1GN, oven base  PNC 922107
- Cupboard stand for oven 10x2/1GN  PNC 922110

APPROVAL: \_\_\_\_\_

- Hot cupboard stand for convection oven 10x2/1GN PNC 922113
- 80mm pitch side hangers for 10x2/1GN oven PNC 922117
- 60mm pitch side hangers for 10x2/1GN oven (included with the oven) PNC 922123
- Feet for ovens 6x1/1GN, 10x1/1 and 2/1GN PNC 922127
- Trolley for 10x1/1GN and 10x2/1GN roll-in rack PNC 922128
- Retractable hose reel spray unit PNC 922170
- External side spray unit (needs to be mounted outside and includes support to be mounted on the oven) PNC 922171
- Pair of baking tray support PNC 922173
- Pair of AISI 304 stainless steel grids, GN 2/1 PNC 922175
- Kit to convert to 10x2/1GN roll-in rack PNC 922202
- Pair of frying baskets PNC 922239
- Grid for whole chicken (8 per grid - 1,2kg each), GN 1/1 PNC 922266
- Kit universal skewer rack and 6 short skewers for Lengthwise and Crosswise ovens PNC 922325
- Universal skewer rack PNC 922326
- 6 short skewers PNC 922328
- Smoker for lengthwise and crosswise oven (4 kinds of smoker wood chips are available on request) PNC 922338

Front

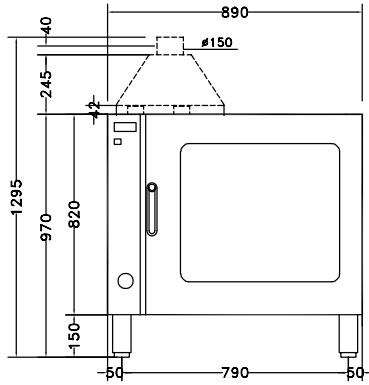

Side

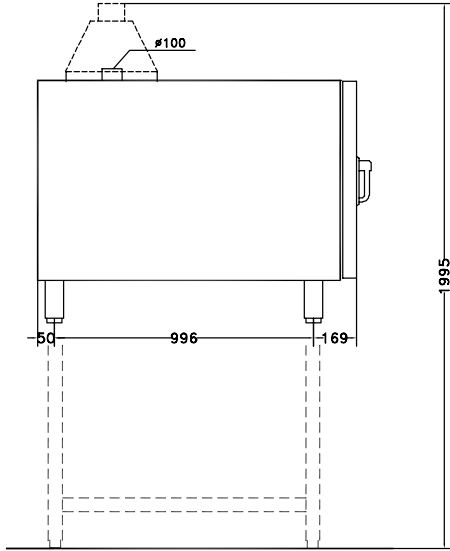

Top

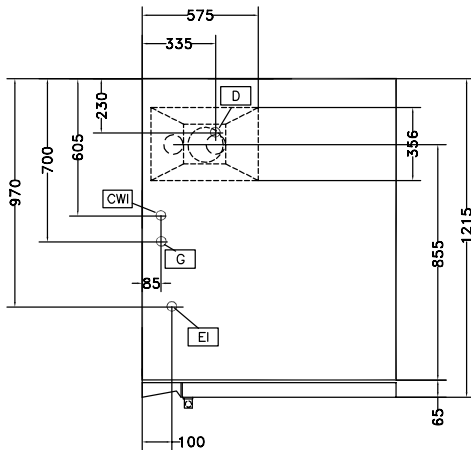

CWI1 = Cold Water inlet 1                      G = Gas connection  
 CWI2 = Cold Water Inlet 2  
 D = Drain  
 EI = Electrical inlet (power)

## Electric

**Supply voltage:**  
 260724 (FCG10260)                      220-230 V/1 ph/60 Hz  
**Auxiliary:**                                      0.5 kW  
**Electrical power max.:**                      0.5 kW

## Gas

**Gas Power:**                                      25 kW

## Capacity:

**Shelf capacity:**                                      10

## Key Information:

**External dimensions, Width:**                      890 mm  
**External dimensions, Height:**                      970 mm  
**External dimensions, Depth:**                      1215 mm  
**Net weight:**                                      154 kg  
**Height adjustment:**                                      80/0 mm  
**Functional level:**                                      Basic  
**Type of grids:**                                      2/1 Gastronorm  
**Runners pitch:**                                      60 mm  
**Cooking cycles - air-convection:**                      300 °C

Crosswise Convection  
 Gas Convection Oven, 10 GN2/1 - 60Hz

The company reserves the right to make modifications to the products without prior notice. All information correct at time of printing.