



GRINDMASTER®

VENEZIA ESPRESSO GRINDER-DOSERS

Project

Date

Models

VGT

VGA

VGHDA

Item#

Quantity



model VGA

FEATURES

- Grinder-Dosers with stepless micrometrical grinding adjustment. Restrictive collar gives the operator infinite grind settings with a simple twist.
- VGT offers a timer version: set the timer to start the grind, machine turns off automatically after time is up. Timer can also be stopped manually. 1 minute maximum grind.
- VGA and VGHDA offer automatic versions: doser chute is always kept full, ready for dispensing. Auto starts every 12 doses, the grinder stops when the chute is full.
- Direct drive, 1600 rpm motor.
- Heavy duty cast aluminum body.
- Overheating safety protection.
- VGT and VGA have 64mm flat precision stainless steel burrs, and grind at the rate of 2.5 g / second.
- VGHDA have 83mm flat precision stainless steel burrs, and grind at the rate of 4.2 g / second.
- Dose adjustment: 5.5g - 9g.
- Quiet running - less than 81 dB.
- Shot counter on doser indicates the number of cups of espresso that have been served.





VENEZIA ESPRESSO GRINDER-DOSERS

model VGHDA

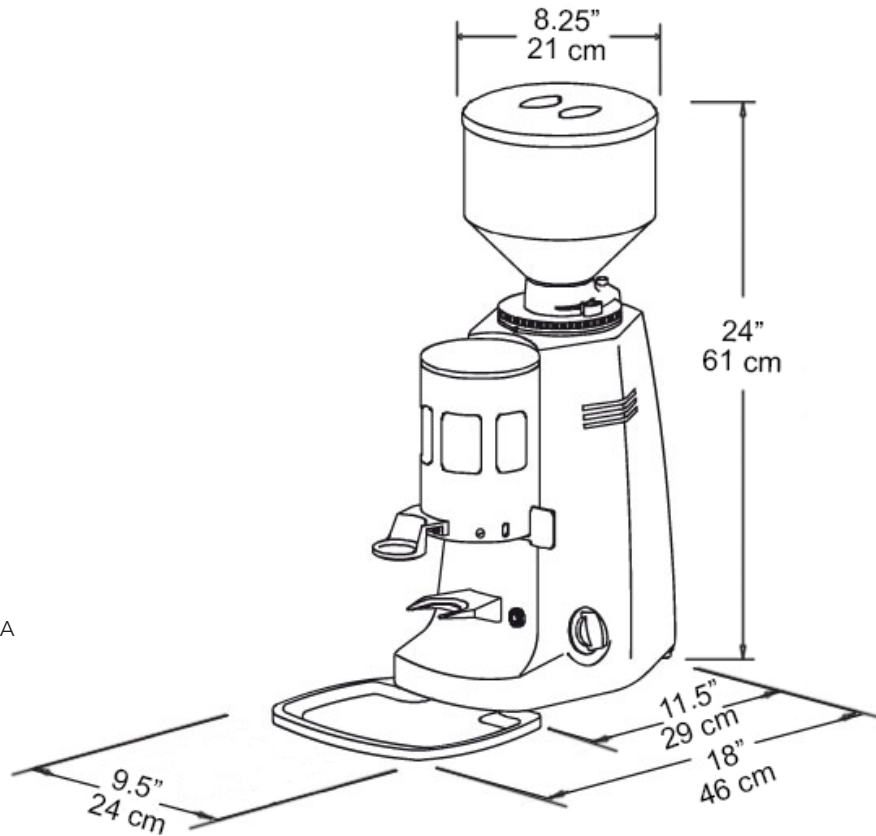

MODELS & SPECIFICATIONS

Model	Description	Grinding	Capacity	Electrical	Product Dimensions (H x W x D)	Ship Dimensions (H x W x D)	Product Weight	Ship Weight
VGT (077800L)	Grinder-doser with 1-minute timer and 0.5 hp direct drive motor. 64 mm flat precision stainless steel burrs.	2.5 g / sec 1600 rpm	Bean Hopper: 2.7 lbs. (1.2 kg) Ground Espresso: 0.6 lbs. (250 g)	120V 0.35 kW 2.9A / 1 Ph	24" x 9.5" x 16.5" (61 cm x 24 cm x 42 cm)	17" x 10.5" x 23.5" (43 cm x 27 cm x 60 cm)	31 lbs. (14 kg)	35 lbs. (15.9 kg)
VGA (077810L)	Grinder-doser - automatic version and 0.5 hp direct drive motor. 64 mm flat precision stainless steel burrs.	2.5 g / sec 1600 rpm	Bean Hopper: 2.7 lbs. (1.2 kg) Ground Espresso: 0.6 lbs. (250 g)	120V 0.35 kW 2.9A / 1 Ph	24" x 9.5" x 16.5" (61 cm x 24 cm x 42 cm)	17" x 10.5" x 23.5" (43 cm x 27 cm x 60 cm)	31 lbs. (14 kg)	35 lbs. (15.9 kg)
VGHDA (077820L)	Heavy duty grinder-doser - automatic version and 1.0 hp direct drive motor. 83 mm flat precision stainless steel burrs, Built in cooling fan.	4.2 g / sec 1600 rpm	Bean Hopper: 4 lbs. (1.8 kg) Ground Espresso: 0.8 lbs. (360 g)	120V 0.65 kW 5.4A / 1 Ph	24" x 9.5" x 18" (61 cm x 24 cm x 46 cm)	25.5" x 8.75" x 11.5" (65 cm x 22 cm x 29 cm)	44 lbs. (20 kg)	44 lbs. (20 kg)

Electrical: NEMA 5-15P line cord included.

Dose adjustment: 5.5g - 9g.

Grindmaster-Cecilware™ 4003 Collins Lane, Louisville, KY 40245 USA

Tel: +1.502.425.4776 / 800.695.4500 (USA & Canada only) • Fax: +1.502.425.4664 • www.gmcw.com • Email: info@gmcw.com

© 2018 Grindmaster-Cecilware™ PRINTED IN USA | 1218 Form # CW-223-04